

# Keysight Technologies

## Designing Automated Tests Using Powerful Digital Acquisition Systems

Application Brief

### Test Challenges:

- Creating a thermal profile of a device under test
- Making mixed-signal measurements

More Application, Information, and Pricing available at:



250 Technology Way  
Rocklin, CA 95765

sales@testworld.com  
1-855-200-TEST (8378)

Click to go [www.TestWorld.com](http://www.TestWorld.com)



## Overview

There are a number of data acquisition (DAQ) systems available on the market today. Still, developing a test system for switching and measurements can be quite challenging. That's because when designing automated tests, engineers need to consider a range of factors, like the I/O with the controller, measurement capabilities, speed, and switching choices.

See our test challenges below to learn how the Keysight Technologies 34970A and 34972A DAQ systems can provide you the versatility, powerful functionality and cost-effectiveness you need to design modern test systems. Also, gain additional insight into a range of design considerations, comparisons to PXI systems and test optimizations; all useful information, regardless of whether you are developing a new system or simply trying to optimize a 34970A/34972A DAQ system.

### Creating a thermal profile of a DUT

You want to create a thermal profile of your Device-Under-Test (DUT). The temperature range is relatively narrow and the fastest rate at which you will sample the data is about 1 sample every 5 seconds. Accuracy is the most important parameter in your measurement. Consequently, you've decided to use a Resistance Temperature Detector (RTD) because it provides the most accurate temperature measurements. To eliminate lead resistance errors, you need a 4-wire measurement that compensates for lead resistance. The 34970A and 34972A DAQ systems feature a built-in Digital Multimeter (DMM) that work easily with RTD arrays. With built-in signal conditioning, the Keysight Technologies DAQ systems can simplify your DAQ wiring and electronics. You can even use a software program to gather and visualize your data.

### Making mixed-signal measurements

Mixed-signal measurements are a common requirement for any test system. In one DAQ system alone, you might measure temperature, flow pressure and high voltages. Making these measurements accurately and efficiently requires a versatile and powerful DAQ system. Using the versatile 34970A DAQ system, or even the newer 34972A DAQ system, you can easily scan high voltage (up to 300 V) points and have a combination of different low voltage points, sensitive transducers and RF signals—all in the same system.

## A cost-effective solution

Often developers use PXI or VXI when designing DAQ systems. However, if you are starting a new system design, you should be aware of the true costs associated with PXI as compared to a 34970A/34972A DAQ system.

With an existing PXI/VXI system, the only consideration is the module cost, which can range anywhere from \$500 to greater than \$2000 USD. When starting a new system design, the cost of the mainframe, cables, interface hardware, and software must be taken into account.

To compare the cost between the two scenarios, consider a configuration with 120 single-ended channels. A 34972A with this configuration will cost less than \$4,000 USD, including the I/O connection to a PC via a readily available USB or LAN cable. In contrast, a new PXI switch system with the same configuration will easily exceed \$6,000 USD, and require the purchase of a card cage, MXI-4 cable and an I/O card for the PC, in addition to switch cards for the 120 single-ended channels.

## Overcoming the I/O challenge

The number of instruments used in a test system often places a heavy burden on the digital input and output (I/O) between the system computer, usually a PC, and the test equipment. One of the best ways to cope with a high volume of I/O traffic—commands, status messages, and test data—is to employ LAN or USB technology. Both are fast, open and low-cost solutions for system I/O and should be considered when designing a new test system. USB and LAN are standard on the 34972A DAQ system.

For systems locked into using GPIB or legacy RS-232, the 34970A DAQ system offers its full support. GPIB and RS-232 are less common on newer systems due to the low cost-of-entry for LAN and USB. None the less, GPIB is a proven I/O standard and has been in use in industrial systems for over 20 years. RS-232 is still in use for low-cost controllers that do not have the other I/Os mentioned.

## DAQ measurements with a DMM

Data loggers like the Keysight 34970A and 34972A DAQ systems use highly accurate, integrating analog-to-digital (A/D) voltmeters to measure the various inputs routed to them via multiplexer cards. The 34970A and 34972A, for example, employ a 6½-digit DMM with a noise floor equivalent to the Effective Number of Bits (ENOB) to 1 bit out of 24 (Figure 1).



Figure 1. Shown here is the 34970A DAQ system with built-in 6½ digit DMM.



## Optimizing measurement and transactional speed

If accuracy is secondary to measurement and transactional speed, here are a few points to consider:

### Transactional speed:

The data acquisition system also spends time parsing commands, controlling auto-ranging, updating the display, and in the case of thermocouple measurements, measuring thermocouple reference junctions and converting thermocouple voltage readings into temperature. These activities all take time. By carefully considering each of these functions, and eliminating those that won't affect required system accuracy, you can substantially improve measurement time.

If you are using LAN and need to reduce the transaction latency, you can optimize LAN transactions by concatenating multiple commands in the same string. For example, sending "ROUT:CLOS (@1001);;ROUT:OPEN (@1001);;ROUT:OPEN?(@1001)," will send three commands in a single string to the DAQ system. Rather than using three different transactions, which include transaction time and latency, sending only one single transactional command can save you 50% of the transaction time.

### Measurement speed:

If you are trying to optimize your measurement speed, there are a number of system overhead settings that you can change. By default, the 34970A/34972A is made to be usable from the front panel and is designed to be user friendly and readable. To get faster readings, simply turn off the display to reduce the processing overhead required to drive the display and buttons.

## Choosing the Right Multiplexer

Multiplexers consist of multiple switches combined so that any one channel is connected to a common output at any given time (Figure 3). Scan speed is affected by the type of switches used in the multiplexer. Electro-mechanical armature relays are rugged and can handle relatively large voltages and currents. Armature relays handle the highest magnitudes, but are relatively slow and only able to switch at a rate of 60 channels per second. Reed relays carry less current, but are faster and are often used in data acquisition scanners. The scanning rate for reed multiplexers is 250 channels per second for the 34970A/34972A.

## Summary

Using a versatile and powerful DAQ system like the 34970A or 34972A, you can easily and cost-effectively design automated tests. A built-in DMM enables the 34970A/34972A to measure the various inputs routed to them via multiplexer cards. Following a few simple measurement tips users can optimize the instruments for throughput, scanning speed, or accuracy. Thanks to the 34970A/34972A DAQ system, designing automated tests has never been easier.

### Measurement tip

To increase your reading speed on the 34970A/34972A:

- If the environment around your data logger is relatively stable, turn auto-zero off.
- Program the DMM range directly rather than leaving the DMM in auto-range mode.
- Set the correct integration time. Integrating over at least one Power Line Cycle (PLC) will reduce the effect of power-line related noise, but limits the measurement speed to 50 or 60 readings per second.
- Turn off the front panel display and keyboard.
- Use constant current sources to measure resistance, which gives you a voltage measurement.
- Measure thermocouple reference junctions less frequently.
- Convert thermocouple voltage measurements to temperature in your computer rather than in the DAQ system itself.

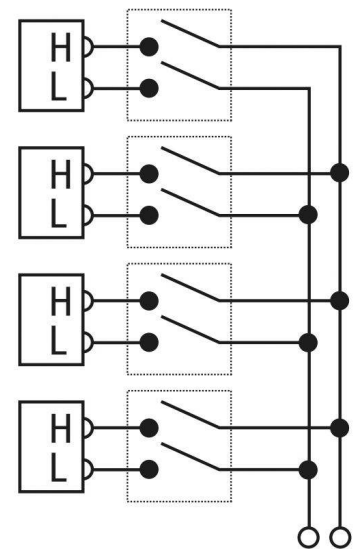

Figure 3. Shown here is a 2-wire, 4:1 MUX.

**myKeysight**

**myKeysight**

[www.keysight.com/find/mykeysight](http://www.keysight.com/find/mykeysight)

A personalized view into the information most relevant to you.

**Three-Year Warranty**

[www.keysight.com/find/ThreeYearWarranty](http://www.keysight.com/find/ThreeYearWarranty)

Keysight's commitment to superior product quality and lower total cost of ownership. The only test and measurement company with three-year warranty standard on all instruments, worldwide.

[www.keysight.com/quality](http://www.keysight.com/quality)

Keysight Technologies, Inc.

DEKRA Certified ISO 9001:2008

Quality Management System

**Keysight Channel Partners**

[www.keysight.com/find/channelpartners](http://www.keysight.com/find/channelpartners)

Get the best of both worlds: Keysight's measurement expertise and product breadth, combined with channel partner convenience.



For more information on Keysight Technologies' products, applications or services, please contact your local Keysight office. The complete list is available at: [www.keysight.com/find/contactus](http://www.keysight.com/find/contactus)

**Americas**

Canada	(877) 894 4414
Brazil	55 11 3351 7010
Mexico	001 800 254 2440
United States	(800) 829 4444

**Asia Pacific**

Australia	1 800 629 485
China	800 810 0189
Hong Kong	800 938 693
India	1 800 112 929
Japan	0120 (421) 345
Korea	080 769 0800
Malaysia	1 800 888 848
Singapore	1 800 375 8100
Taiwan	0800 047 866
Other AP Countries	(65) 6375 8100

**Europe & Middle East**

Austria	0800 001122
Belgium	0800 58580
Finland	0800 523252
France	0805 980333
Germany	0800 6270999
Ireland	1800 832700
Israel	1 809 343051
Italy	800 599100
Luxembourg	+32 800 58580
Netherlands	0800 0233200
Russia	8800 5009286
Spain	0800 000154
Sweden	0200 882255
Switzerland	0800 805353
	Opt. 1 (DE)
	Opt. 2 (FR)
	Opt. 3 (IT)
United Kingdom	0800 0260637

For other unlisted countries:  
[www.keysight.com/find/contactus](http://www.keysight.com/find/contactus)  
(BP-07-10-14)